

LifePlus[®] Decking Guide

A Guide to the Properties of

LifePlus[®] Decking &

The LifePlus[®] Decking System

LifePlus® Decking & The LifePlus® Decking System

Covered verandahs and decks are a recognised and valued feature of Australian architecture, providing protection for external walls from the weather in particular the heat of the sun. In more contemporary design, a deck, whether covered or exposed to the weather and incorporated as part of new home construction or added to an existing home, can provide an enjoyable outdoor entertaining or BBQ area. Decks enhance our modern lifestyle by extending internal living areas into the outdoors.

A timber deck can create an attractive surround for a pool particularly on a sloping site.

A raised platform deck is an excellent way of dealing with problem building sites. On uneven, sloping, rocky or poorly drained land you can extend your livable area into space that would otherwise be unused.

In high-density residential developments or light commercial applications a timber deck or walkway can bring a feeling of nature and open space into modern design concepts.

LifePlus® Decking is a unique and high quality hardwood timber decking which has been developed to enhance the enjoyment of outdoor decking areas by delivering improved performance and longer life in fully weather-exposed conditions.

The LifePlus® Decking System is an integrated system of best practices in design; construction and finishing materials; and construction, installation, finishing and maintenance practices developed to deliver a satisfying decking project which performs well over a long life.

LifePlus® Decking features

- A unique and improved decking profile in hardwood which delivers improved performance and longer life;
- Selected Australian hardwoods recognised as delivering superior performance in fully weather-exposed conditions;
- Manufacturing to a high standard on the exposed face for improved weathering performance;
- Treatment with a non-chrome and non-arsenic preservative.



Introduction

This LifePlus® Decking Guide has been written for domestic applications, in non-bushfire rated areas, and has been developed to assist consumers, designers and builders to deliver a decking project which gives satisfying and trouble free performance over the long term, ensuring that the lifestyle benefits that are expected from a timber deck are delivered in practice.

The Guide has been developed for fully weather-exposed decks, which place vastly greater demands on structural timber, decking and fixings. As a result, you will find many recommendations for use of materials and techniques which are of a higher standard than general practice. In particular, some attention is given to the requirement for suitable fixings and the protection of structural and decking timber. However, the best protection for a timber deck comes in the form of a roof with wide overhangs to shelter the timberwork from sun and rain.

Why is such a Guide necessary?

In the traditional delivery of decking projects there is a strong emphasis on the choice of the timber decking. In some cases a particular look or feel may be the determining factor. In other cases cost may dictate the type of decking chosen. However there are many elements to a decking project, all of which are important for satisfying performance.

Dissatisfaction with a timber decking project can result from:

- Problems occurring in the short term – normally related to poor performance of the decking - distortion, excessive swelling and shrinkage or fixings working out or failing
- Problems occurring in the longer term - normally related to premature deterioration of the decking, subframe or fixings, or failure, if the premature deterioration is not recognised.

These problems can originate in a number of areas including:

- design and/or detailing
- choice of decking or structural timber
- choice of other materials
- construction of the subframe
- installation of the decking
- finish chosen or finishing techniques
- maintenance of the decking.

For a decking project to provide satisfying performance and long life, each element of the project must be individually considered and integrated into a total project solution.

By employing the LifePlus® Decking System a timber decking project can be delivered which gives satisfying performance over a long life, avoiding the problems of poor performance or premature deterioration.

The LifePlus® Decking System combines good practices in:

- design and detailing
- choice of quality, and suitable, materials for the subframe, decking, fasteners and finishes
- foundation and subframe construction, and
- decking installation, finishing and maintenance.

The benefits of this “system” approach become more apparent in the medium to long-term as other decking projects without this approach may suffer from poor performance, premature deterioration and reduced enjoyment by its users.

An important element of the LifePlus® Decking System is LifePlus® Decking itself, which has been developed as a high quality timber decking, which owners, designers and builders can specify in the confidence that it will give many years of satisfying service in combination with other elements of the LifePlus® Decking System.

The LifePlus® Decking Guide is set out in the same way that you would work through a project. From concept, design and construction of the foundations and subframe to decking installation and finishing and maintenance. We suggest that you read the Decking Guide thoroughly first to gain a mental picture of where you are heading and how you will get there.

This is also important, as there are some choices to be made initially which must be consistently followed through the project. For instance the choice of timber sealer which you may start applying at the early stages of the project is determined by the choice of the timber finish which you will be applying at the end of the project.

We wish you success and many years of satisfying performance from your timber deck.



Contents

CONCEPT STAGE	4	CONSTRUCTION STAGE	13
		Setting out	14
DESIGN STAGE	5	Footings	14
Timber selection	6	Posts and ledgers/pole plates	14
Floor plans	8	Bearers	15
Deck height	8	Joists	15
Positioning of post, bearer and handrails	8	Bracing	16
Posts	9	Decking	16
Bearers	9	Finishing	18
Joists	9	Handrails	20
Decking	9		
Bracing	9	CARE OF YOUR DECK	20
Termite protection	9	Maintenance	20
Span Tables	10		
		SAFETY	21
PRIOR TO CONSTRUCTION	11		
Under deck conditions	11		
On-site storage	12		
Sealing cut-ends and joints	12		
Protective timber finishes	12		
Suitable fixings	13		
Existing garden features	13		

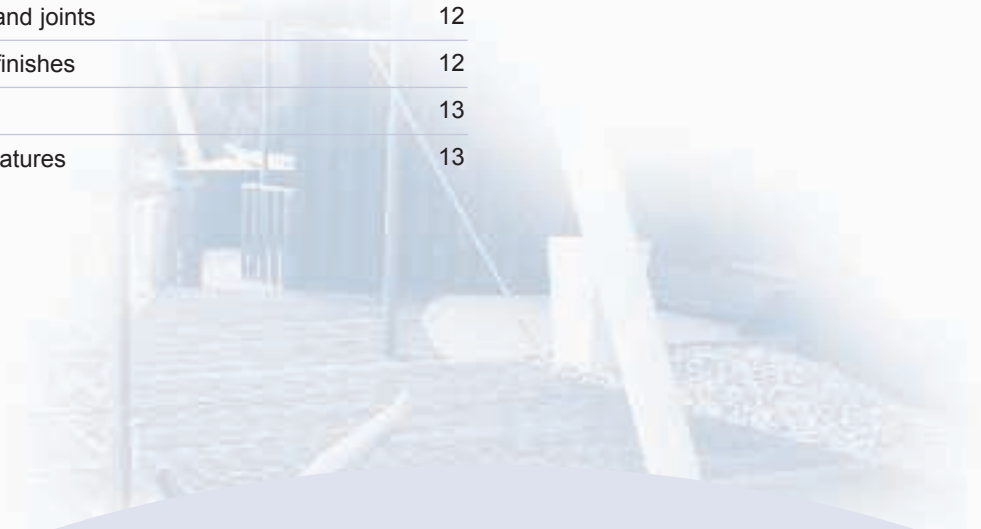

Concept Stage

Careful planning of your decking project is essential.

Start planning for your deck by considering the activities your deck will accommodate, whether it will be a sunny breakfast area, a safe play area for children, or a place for barbecues and entertaining.

Some considerations when developing the concept for your deck should include:

- The size you will need and shape you would prefer, and how it will influence the circulation from inside and outside your home - 2 to 2.5 square metres per person, standing, plus furniture and circulation spaces, is a reasonable starting point for calculating the area you will need.
- The size of your current or anticipated outdoor furniture - allowing appropriate circulation space even when chairs are pushed out.
- The position of your deck - will the deck affect your security or intrude on a quiet area of the home? Will it be sunny in winter, shady in summer or protected from blustery winds?
- If your deck is to be a thoroughfare or incorporate a stairway, is there a clear space for people to walk through without having to avoid furniture or plants or intruding on social gatherings?

Draw a plan of your deck

Draw the plan to scale on a drawing of your house to check the usability of your deck e.g. the size and position of furniture, circulation spaces and standing areas. Check for other impacts, such as access to other areas of your yard, clearance from property boundaries and possible intrusion on utilities such as electricity, water and drainage lines. If you have any doubts as to requirements for separation from utilities, or where they may be located, be sure to contact your provider, employ a professional services locator and maintain the required separation.

Ideas for your deck

A handy source for ideas for the concept of your deck is house, garden and landscaping magazines. However, keep in mind that the projects are often the best of their type and often carry a high price tag. Generally, a simple design will be less expensive to build than a complex one and medium length spans require smaller cross-section timbers, which are more readily available and cheaper.

If considering building a screened area, it is necessary to insect proof the underside of the decking. This can be achieved by attaching metal insect screening to the underside of the joist. The screening can then be removed (not necessarily easily), if required, for cleaning any debris that falls through the decking. Placing the screening between the joist and decking would be a neater solution but would be more difficult to clean.

Building approval

You will need building approval for your decking project, so consult with your local building authority for building requirements in your area.

Involving a designer

You may feel more confident dealing with a designer or draftsman for preparing the working drawings. However, the more thought that you put into deciding what you want from your deck - what it is to look like, the size and positioning, before consulting the designer, the less costly your drawings should be.

Be sure that the designer has a copy of this Guide, that the drawings specify that LifePlus® Decking is to be used and that construction is to be in accordance with the LifePlus® Decking Guide.

Pool safety

If you intend to use some part of your deck as part of a pool feature, consult your local building authority for pool safety requirements.

Tannin staining (timber staining)

All hardwoods release tannins during weathering. Release of tannins is initially high and reduces over time as the tannins are washed from the surface. The dripping of water containing tannins will not affect natural ground, but will stain expensive brickwork or tiles.

Tannin staining can be reduced by using standard or custom made "drip strips" to direct water away from walls. The area under a fully exposed timber deck should not be used for a purpose where tannin staining may be an important issue.

Buying kiln-dried hardwood does not remove the tannins - it simply dries them out and they are reactivated on exposure to moisture from wet weather.



Design Stage

Design Standard

The decking project shall comply in all respects with the Building Code of Australia (BCA).

This Decking Guide provides additional information on good practices in design, construction, installation and finishing to deliver a decking project which performs well over a long life

The diagram below illustrates the terminology for deck construction used in this Guide.

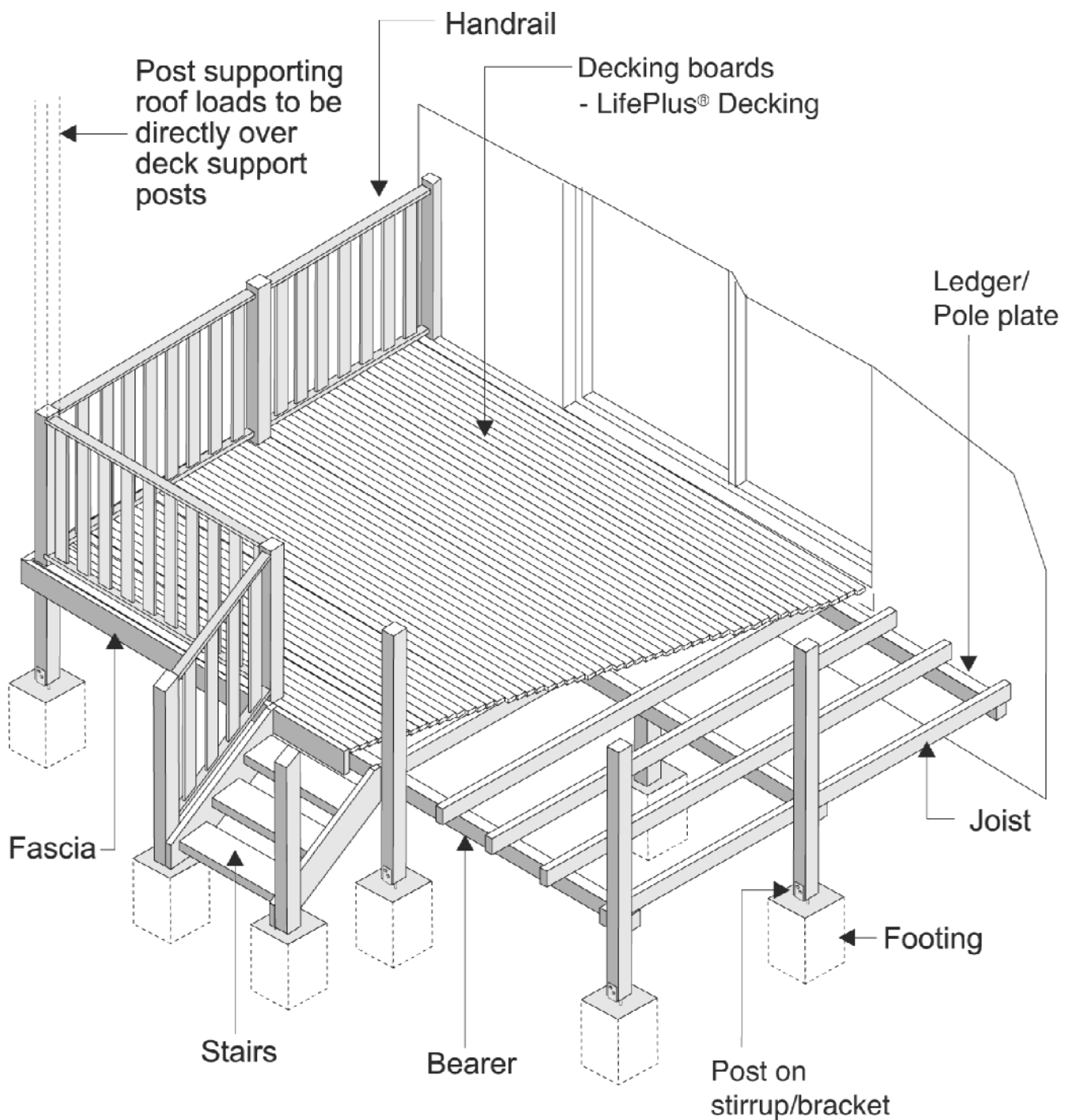

Timber Selection

Timber requirements for building a deck fall into two categories:

timber for the structure

- decking subframe and roof structure

decking timber

There are different requirements for the timber for each category.

Timber for the structure

Structural timber shall have appropriate strength, quality, durability, shrinkage and weathering characteristics and termite resistance to give satisfactory performance over the life of the deck.

As the structural timber is often not directly exposed to the weather and is generally orientated vertically so that the water does not pool in any defects, it can be of a lesser quality and allow a greater range of species than the decking timber.

Suitable structural timber can be sourced in hardwood or softwood.

Strength (Stress Grade)

Specifying timber requirements according to strength (or stress grade) will only ensure that the timber supplied is of sufficient strength, when first installed, to perform a structural purpose.

Commonly available stress grades in unseasoned structural hardwood are F14 and F17 with F7 being commonly available in seasoned softwood.

In hardwood, the timber strength specified may depend on availability in your area, however, **F14 should be the minimum stress grade specified in**, considering the type and extent of natural characteristics allowed under the grading rules for the various stress grades. F17 Hardwood is preferred for weather exposed conditions as it generally includes a lesser number and size of natural characteristics, which can be a source of accelerated deterioration when exposed to the weather.

Note on lower hardwood stress grades: In some areas, hardwood structural timber may only be readily available in lower stress grades and lower durability. Structural timber in F11 stress grade may be suitable, provided that it is: minimum durability class 2 above ground; of low shrinkage or seasoned; well ventilated; not used in conditions of consistent high humidity and used in combination with other good building practices, particularly the sealing of cut ends and sealing of the tops of joists with a waterproof membrane to shed water away from the joist. For structural timber of durability class 2, these requirements would be necessary to satisfy the performance requirements of the BCA.

In softwood, seasoned F7 should be the minimum stress grade specified.

Softwood structural timber shall be well ventilated; not used in conditions of consistent high humidity and used in

combination with other good building practices, particularly the sealing of cut ends and sealing of the tops of joists with a waterproof membrane to shed water away from the joist.

Stress grades are often used as a primary specification for timber used externally, above or in ground. However, stress grades are an imperfect guide for overall suitability of timber for fully weather exposed conditions as other characteristics, such as quality, durability, shrinkage, and weathering properties, are also important.

Quality

Timber supplied to a stress grade will contain natural characteristics, such as knots, to the extent allowed in the grading rules and will not guarantee supply to a visually attractive standard that you may consider appropriate for your situation.

You may prefer that the posts supporting the roof structure and the roof timbers be of a higher standard of appearance, containing few and small characteristics, whereas the decking subframe may only need to be of the specified structural standard, as it is concealed from view. **If you require a high standard of appearance in addition to appropriate strength, specify 'Structural Appearance Grade'.**

Structural appearance grade timbers are more expensive than structural grade timbers. **If the appearance of your structural timber is an issue which is important for your project, speak to your timber merchant about the visual standard of the timber which would be supplied.**

Note: If you are intending to paint your structural timber – a little filler covered by paint can improve the appearance greatly.

Durability

Natural durability is the ability of the heartwood of a timber species to resist decay and insect attack and is determined by the extractives eg oils, waxes and resins which fill the capillaries, and change sapwood into heartwood. Durability ratings have been determined from the performance of samples of heartwood both in-ground and above-ground at a number of test sites around Australia, from expert opinion and from experience of in-service performance.

Durability is categorized into 4 durability classes – from Class 1 for highly durable species to Class 4 for non-durable species, with each durability class having a probable life expectancy for “outside above ground” and “in ground contact”¹.

Durability classes only refer to the heartwood. Sapwood is considered to be non-durable and must be preservative treated to improve its durability. Treatment of sapwood does not improve the durability of heartwood.

The sapwood of some timbers cannot be preservative treated and hence can not be made durable.

It would be expected that the life expectancy of timber *above-ground* would be better than *in-ground*, reflected in the above-ground rating for a species being the same as or better than the in-ground rating.

We recommend that only durability class 1 hardwoods, or appropriately treated seasoned softwoods be considered for use for each of the in-service conditions “outside above ground” and “in ground contact”.

Where the underside of the structure is greater than 400mm above the ground this should be considered an above-ground application and subframe timbers shall be: selected durability class 1 (outside above ground classification) structural hardwoods with sapwood treated to H3 (hazard level 3); or structural softwoods treated to H3.

Where the underside of the structure is less than 400mm above the ground, this should be considered an in-ground contact application and subframe timbers, shall be selected termite resistant durability class 1 structural hardwoods (in ground contact classification) with sapwood treated to H5; or structural softwoods treated to H5.

Posts extending into footings shall be selected durability class 1 hardwoods (in ground contact classification) with sapwood H5 treated or H5 treated round softwood posts.

Note that using termite resistant species does not negate the requirement for termite protection in accordance with the Building Code of Australia.

Shrinkage

If using unseasoned hardwood structural timber, use only low shrinkage timbers ie in the order of 6% to 8% tangential shrinkage. Ideally, a single species, or alternatively mixed species *but with similar characteristics*, shall be used to ensure that similar shrinkage occurs in all the structural members.

High shrinkage species (tangential shrinkage greater than 10%) of unseasoned hardwood structural timber are sometimes supplied for the decking subframe. High shrinkage species are subject to collapse, distortion and excessive reduction in section size during on-site seasoning.

- 2 Treatment is to be by an approved waterborne treatment formulation and vacuum pressure impregnation in an approved industrial facility. We recommend treatment with the latest generation TANALITH® E wood protection from Koppers-Arch.
- 3 Hazard level 3 defines outside, above ground conditions, subject to periodic moderate wetting and leaching.
- 4 Hazard level 5 defines outside in ground conditions, subject to extreme wetting and leaching, in contact with or in fresh water, and/or where critical use requires a high level of protection.
- 5 These species are classified in AS 5604 - 2003 as durability 1 outside above ground and durability 2 in ground contact.
- 6 Blackbutt (*Eucalyptus Pilularis*) is not to be confused with, and should be used in preference to, New England Blackbutt (*Eucalyptus Andrewsii*) which has a lower durability and higher shrinkage than Blackbutt. Blackbutt is best used under cover.
- 7 The species are classified in AS 5604 - 2003 as durability 1 outside above ground and durability 1 in ground contact.
- 8 Forest Red Gum (*Eucalyptus tereticornis*) – sometimes referred to in Queensland as “Blue Gum” - is a high durability & low shrinkage timber suitable for external use & is not to be confused with “Sydney Blue Gum” (*Eucalyptus saligna*) which is a low durability & high shrinkage timber unsuitable for weather exposed use.
- 9 Grey Gum (*Eucalyptus Propinqua*) is a high durability & low shrinkage timber suitable for external use & is not to be confused with “Mountain Grey Gum” (*Eucalyptus Cypellocarpa*) which is a low durability & high shrinkage timber unsuitable for external use.
- 10 Standard trade names from Technical Pamphlet 1 - Building Timbers - properties and recommendation for their use in Queensland - published by Queensland Forest Service.

High shrinkage and widely varying differential shrinkage between species, over time can result in unevenness in the decking surface, unsatisfactory appearance and even structural problems.

If using unseasoned hardwood, confirm with your timber supplier that low shrinkage species will be supplied.

“Surface checking” will occur in unseasoned hardwood as the outside of the section dries out quickly and shrinks while the inside of the section dries more slowly.

Surface checks will close up in the long term as the whole of the section dries out. In low shrinkage timbers the surface checking is normally not severe and we would advise against using a filler to fill surface checks as the filler will be squeezed out as the checks close over time.

If using softwood structural timber, use only seasoned timber for reduced distortion of the structural members and greater stability and uniformity of the overall subframe.

Weathering Characteristics

Weathering is the gradual deterioration of the timber surface from the combined effect of exposure to ultra-violet (UV) radiation in sunlight and water from rainfall. The combined effect is for colour change, a loosening of the timber fibres and a gradual wearing away of the surface.

The swelling and shrinking associated with wetting and drying can cause surface and deeper level checking, and exposure to the heat from direct sunlight can cause distortion of decking. The effect of hot, direct sunlight on saturated timber after rain can be particularly severe. **The natural properties of some timbers, in resisting excessive swelling and shrinking, surface checking and distortion, make them more suited to weather-exposed conditions than other timbers. Similarly, some timbers have natural properties which are not suited to weather exposed conditions and their use should be avoided.**

Maintaining an effective surface coating will improve the performance of the timber work, protecting it from weathering damage.

Suitable Structural Hardwoods

Suitable hardwoods for structural timberwork, include: (notes opposite provide additional essential information)

- For above ground⁵: Spotted Gum and BlackButt⁶
- For above & in ground⁷: Iron Bark, Forest Red Gum⁸, Grey Gum⁹, Grey Box (Gum-topped Box), White Mahogany, Tallowwood and Gympie Messmate.

Any regional high shrinkage examples of these hardwoods are to be avoided.

These are “standard trade names¹⁰”. There are many species referred to by local names which are similar to standard trade names but which may have different properties. **Ensure that species with similar or local names but with inferior properties are not substituted for the species listed above.**

High shrinkage unseasoned timbers and/or low durability timbers and/or timbers with untreated or untreatable sapwood are generally not suitable for structural timbers in weather exposed conditions.

The list of suitable structural timbers, above, is not exhaustive. Contact your local timber industry body for information on the suitable structural timbers which are available in your area.

The supply of suitable unseasoned structural hardwood should be ensured by specifying stress grade, appropriate timber species, treatment level (particularly if H5 is required for in-ground contact conditions) and appearance quality (if required) .

Suitable Structural Softwoods

The supply of suitable structural softwood should be ensured by specifying seasoned F7 softwood and treatment level (particularly if H5 is required for in-ground contact conditions).

Decking timber

LifePlus® Decking is an improved solid timber decking, which delivers longer life plus improved performance in comparison to traditional decking.

Specify LifePlus® Decking with confidence.

The nominal dimensions of LifePlus® Decking are 88mm wide x 21mm deep.

The LifePlus® Decking profile is an improvement on the shape of traditional decking and incorporates:

- **A warp-reducing groove and ripple on the underside**, which reduces distortion and improves ventilation between the decking and joist, making the decking and joists last longer, and
- **Tapered sides**, which assists in self cleaning of the deck, by allowing any debris which enters the gap between the boards to fall through and improves ventilation between the decking and joist.

LifePlus® Decking is available as:

- **LifePlus® Natural Decking**, which has a **natural textured exposed face**, for situations where improved slip resistance is a consideration or where a more natural appearance is preferred.
- **LifePlus® Classic Decking**, which has a **smooth dressed finish**, for situations where a traditional appearance is preferred and slip resistance is not a consideration.

The exposed surface of **LifePlus® Natural Decking** is sanded during machining, removing loose splinters and leaving the natural textured form of the sawn surface. The natural face also performs better than a dressed face when exposed to the weather.

LifePlus® Decking is manufactured from "selected hardwoods" - high quality, durability 1 (outside above ground classification) treated hardwoods with proven durability, stability and weathering characteristics to deliver superior performance in weather exposed conditions.

LifePlus® Decking is not produced from "mixed hardwoods", which can be supplied from a variety of hardwood species including some which are of lower durability, higher shrinkage and lower stability than we would consider acceptable.

LifePlus® Decking is supplied as a dried product with a maximum moisture content of 15%. If decking is to be installed in areas of consistent extreme low humidity, eg in drier far western areas or in areas of consistent extreme high humidity, eg in rainforest areas, then decking with an appropriate moisture content shall be ordered, or standard decking acclimatised to the local EMC (equilibrium moisture content) by strip-stacking before installation.

The equilibrium moisture content (EMC) is the moisture content at which the timber no longer loses moisture to, or gains moisture from, the atmosphere. The EMC varies with seasonal changes, so it is normal to quote a range for a location.

Minimal shrinkage or expansion will occur if timber is used with a moisture content within the EMC range for a location.

Mt Isa, in north-western Queensland, has an average EMC of 9-10% and timber shrinkage associated with moisture loss to the atmosphere, from say 15% down to 9% is likely to produce excessive gapping, possibly board distortion and reduction in hold-down from the fixings.

If using decking with standard moisture, in areas of low or high humidity, make suitable allowance for the corresponding shrinkage or expansion which will occur.

The greatest enemy of exposed timberwork is moisture. Decking projects in high humidity or rainfall areas require greater attention to design, detailing, construction and regular maintenance. Consider using Durability 1 Hardwoods (in-ground contact classification), or protecting your deck with a roof with wide overhangs.

Floor Plans

Draw several floor plans of the deck to scale (e.g. 1mm = 20 to 50mm) until you are satisfied that you have drawn the concept to a size and shape that best suits your overall requirements.

Deck Height

Calculate the relative levels of bearers, joists and decking so that the finished level of your deck is lower than the internal house floor by 25mm to prevent water from your deck running back into the house – see Figure 6 (page 16). Take into account that unseasoned subframe timbers will shrink as they season, with the finished level, when seasoned, being lower than when first constructed.

Positioning of Posts, Bearers and Handrails

Choose the type of handrail for your deck. Consider how it will be attached to the post and whether the post will be a continuation of the support post or be freestanding and bolted to the bearer. Consider whether the bearer will be attached to the front or back of the post and whether it will be attached to the face of the post or checked-in.

Draw an end section of your proposed handrail configuration to confirm that the post, bearer, joist, decking and handrail configuration can be constructed as envisaged.

Posts

Mark the posts in at the corners. Then mark in an economical grid of intermediate posts derived from Table 2 'Bearers' (page 10). Use bearer spans 2.4 m or less for economy.

Bearers

Draw in the rows of bearers as broken lines connecting the posts and write in the size according to Table 2. Note that the decking boards will be oriented in the same direction as the bearers. This may be an important consideration in deciding on the direction that your bearers, joists and decking run. Unless other design restrictions dictate the orientation, where possible, design your bearer and joist orientation so that the decking boards are laid in the same direction as the longest open face of the deck exposed to the weather and not as a large number of same length boards across the deck. If a section of deck becomes weather damaged it will then only be necessary to replace some runs of boards rather than replace all the boards or cut and replace the damaged ends of the boards, which is a less than ideal repair job.

Joists

Draw the rows of joists as solid lines at 90 degrees to the bearers and spaced at 450mm centres for LifePlus® Decking. Write in the joist size, derived from Table 3 - 'Joists' (page 10) and spacing.

Wider joists (ie 50mm unseasoned hardwood, 42mm seasoned hardwood or 45mm seasoned softwood) shall be used to allow the placing of fixings in a formal staggered alignment/pattern, thereby reducing the likelihood of split joists. Wider joists are also better for joining of decking boards over the joist as the fixings can be placed further from the end of the board, thereby reducing the likelihood of the fixing splitting the end of the board. Narrower joists (38/35 mm wide) can be structurally adequate at an appropriate depth but are not recommended.

Note: Do not position joists above the support posts. Posts normally only shorten marginally as they season. However unseasoned bearers and joists will shrink and as a result the whole deck will settle. This is normally not noticeable or an issue. If the post has been cut off level with the bearer initially, and the joist has been positioned above the post, then as the bearer shrinks, the joist will be lifted off the bearer.

If looking at having timber decking as part of a steel-framed home, it may be necessary to incorporate timber joists into your steel system as direct fixing of timber decking to metal joists with self drilling screws may result in a weakening and eventual failure of the screw in the long term.

Please refer to your steel framing supplier for further information on how timber decking can be incorporated into the design.

Decking

Specify LifePlus® Decking for high performance and long life from your decking timber. Calculate the approximate quantity of LifePlus® Decking required from the formula:

$$\left\{ \frac{\text{Width of deck (metres)} \times 1000}{\text{Width of board} + \text{gap (mm)}} \right\} \times \text{Length of deck (metres)} \times 1.1$$

Note: The 1.1 multiplier represents 10% added for wastage in cutting random length decking to fit the set spacing of joists.

Bracing

Bracing must be provided for stability of the deck – refer to 'Bracing' (page 16).

Termite Protection

Termite protection shall be provided in accordance with the requirements of the Building Code of Australia.

The hardwoods previously advised as suitable for structural timberwork are resistant to termite attack¹¹.

However, in addition to the deck potentially being subject to termite attack, the deck may become a means of access for termites to the dwelling to which the deck adjoins and termite protection must be incorporated into your design – particularly as untreated softwood is commonly used as a framing timber in houses. Termite attack of non-structural timbers such as architraves can be worrying and costly to repair but termite attack on untreated framing can affect the structural integrity of your home and be very expensive to repair.

Termite protection may take the form of combinations of the following:

- Keeping the under-deck and surrounding area dry;
- Keeping gardens and landscaped or mulched areas away from the deck;
- Using termite resistant timber species;
- Performing perimeter chemical treatment, and/or treatment of the sides and base of any post hole;
- Installing termite barriers such as metal ant capping eg. where the deck joins an adjacent structure;
- Performing regular competent physical inspection of the structure and inspection points;
- Designing in gaps between members at critical and easily accessible locations e.g. setting posts on metal brackets with a 75mm gap between the post and concrete or designing a separate, free-standing deck with a 75mm gap to any adjacent structure. (Continued page 11)

¹¹ Termite Resistant Species are nominated in AS 3660.1.

Span Tables for Decking Subframe Timbers

to Support Decks Greater than 1000mm above the Ground in Wind Classification Areas N1 to C3 in F14 Unseasoned Hardwood (U/S F14). **For tables for F7 Seasoned Softwood refer AS 1684.2 - 1999**

Terminology: D - member depth, B - member breadth, C'lever - Cantilever (mm), NS - not suitable

RM – Refer to merchant for availability and lead times for long lengths &/or large end sections

Table 1 Posts supporting Deck only or with Roof

	Floor Load Area (m ²)											
	5				10				20			
Roof Load Area (m ²)	0	10	20	40	0	10	20	40	0	10	20	40
Post Size U/S F14 DxB (mm)	Maximum Post Height (mm)											
	Sheet Roof											
75x100	3000	2700	2100	NS	2100	2000	1900	NS	1400	1400	1300	NS
100x100	4600 RM	4100 RM	3300	2300	3300	3100	2900	2300	2300	2200	2200	2000
	Tile Roof											
	75x100	3000	2400	1800	NS	2100	1800	1600	NS	1400	1300	1200
100x100	4600 RM	3700	2900	2000	3300	2900	2600	2000	2300	2100	2000	1700

The above table was based on a maximum Sheet Roof Mass of 40 (kg/m²), Tile Roof Mass of 90 (kg/m²), Total Upper Floor Mass of 40 (kg/m²) & Floor Live Load of 3.0 (kPa).

Table 2 Deck Bearers

Bearer Size U/S F14 DxB (mm)	Floor Load Width (mm)									
	1200		1800		2400		3600		4800	
	Maximum Bearer Span (mm)									
	Span	C'lever	Span	C'lever	Span	C'lever	Span	C'lever	Span	C'lever
	Single Span									
	100x75	2000	600	1600	400	1400	400	1100	300	1000
125x75	2500	700	2100	600	1800	500	1400	400	1200	300
150x75	3000	900	2500	700	2200	600	1800	500	1500	400
175x75	3400	1000	2900	800	2500	700	2100	600	1800	500
200x75	3800	1100	3400	1000	2900	800	2400	700	2000	600
225x75	4200	1200	3700	1100	3300	900	2700	800	2300	600
250x75	4500	1300	4100	1200	3700	1100	3000	900	2600	700
	Continuous Span									
	100x75	2000	600	1600	400	1400	400	1100	300	1000
125x75	2600	700	2100	600	1800	500	1400	400	1200	300
150x75	3100 RM	900	2500	700	2200	600	1800	500	1500	400
175x75	3600 RM	1000	2900	800	2500	700	2100	600	1800	500
200x75	-	-	3400 RM	1000	2900	800	2400	700	2000	600
225x75	-	-	-	-	3300 RM	900	2700 RM	800	2300	600
250x75	-	-	-	-	-	-	3000 RM	900	2600	700

The above table was based on: Maximum Deck Mass of 20 (kg/m²), Floor Point Load of 1.8 (kN), Balcony Live Load of 3 (kPa) Minimum Backspan = 200% of Overhang, Maximum Overhang = 30% of Backspan, End bearing lengths = 50 mm at end supports and 100mm at internal supports for continuous members

Table 3 Deck Joists - Joist Spacing 450mm

Joist Size U/S F14 DxB (mm)	Maximum Floor Joist Span (mm)			
	Span	C'lever	Span	C'lever
	Single Span		Continuous Span	
100x50	2300	600	2600	700
125x50	2900	850	3300 RM	850
150x50	3500	1050	-	-
175x50	3900	1100	-	-
200x50	4400	1300	-	-
225x50	4800	1400	-	-
250x50	5200	1500	-	-

The table opposite was based on:

Maximum Deck Mass of 20 (kg/m²), Floor Point Load of 1.8 (kN) & Balcony Live Load of 3 (kPa)

Minimum Backspan = 200 % of Overhang,

Maximum Overhang = 30 % of Backspan

End bearing lengths = 35 mm

Internal bearing lengths = 70mm

Joists 2.4 and longer used at the maximum span allowable in Table 3 may exhibit some flexibility or “bounce”. To achieve a stiffer deck, use joists one size greater than given in the table.

Table 4 Recommended Fixing for LifePlus® Decking - in weather exposed domestic applications subject to light volumes of foot traffic.

Method - Hand nailing or screwing with 2 fixings per board at each joist in a formal staggered pattern

Screws - LifePlus Decking Screws - 10G x 50mm Stainless Steel, Square Drive, Self Embedding Head

Nail Type - Domed Head (DH), Twist Shank (TS), Stainless Steel (SS) (preferred) or Hot-Dipped Galvanised (HDG) nails

NailSize - For hardwood joists use 50x2.8mm DHTS SS or HDG. For softwood joists use 65x3.15mm DHTS SS or HDG.

Note: Termite barriers and gaps will not necessarily stop access by termites as physical or chemical barriers can be bridged or breached. Often, access by termites in susceptible timbers is “through” the timber, eating from the inside, rather than along it, so that their presence is not obvious until the later stages of attack. Termite barriers and gaps make any access noticeable, by forcing the termites to build a bridge or tunnel, where it can be seen, over the barrier or gap.

It is essential that an easy means of access to the underside of your deck be provided and regular competent inspection be undertaken (eg six monthly) for signs of termite activity, such as termite tunnels or trails, or to re-treat where a chemical treatment has been used.

Do not disturb any termite tunnels or trails if they are found. Rather, contact your pest treatment professional immediately for urgent treatment. Ensure that the person performing the treatment has completed the relevant timber treatment modules of the pest treatment certification process.

Further information on choosing a reputable pest controller can be obtained from the Australian Pest Controllers Association.

Notes to Tables (shown on page 10)

- Joists and Bearers are not to carry roof loads (i.e. any roof or pergola supports are to be directly above the deck supports).
- Maximum joist spacing for LifePlus® Decking is 450mm centres.
- Wider joists (ie 50mm unseasoned hardwood, 42mm seasoned hardwood or 45mm seasoned softwood) shall be used to allow the placing of fixings in a formal staggered alignment or pattern, to reduce the risk of splitting the joist and for better joining of decking boards over the joist as the fixings can be placed further from the end of the board. Narrower joists (38/35 mm wide) are not recommended.
- For other stress grades or larger spans refer to AS 1684 Residential Timber Framed Construction.
- Choice of Stainless Steel or Hot-dipped Galvanised is dependant on severity of exposure conditions. In corrosive environments such as in coastal areas or around pools, fixings shall be stainless steel.
- Although 50x2.5 stainless steel domed head gun nails are readily available and commonly used for fixing decking, **we recommend hand nailing** with the nail type and size listed Table 4, as they provide greater initial hold-down and have sufficient history of use to be confident of long term performance. If required, your nail supplier may be able to provide additional information on gun nails for decking and a recommendation as to their suitability.
- 50 x 2.8 Galvanised Bullet Head Nails may be suitable for fixing hardwood decking to hardwood joists in *weather protected domestic applications*, where decking is not subject to the stresses associated with exposure to sun and rain and high volumes of foot traffic and where the lesser hold-down forces from a straight shank and bullet head nail may be acceptable for long term performance -

refer to your supplier or nail manufacturer for advice as to suitability.

- Floor Load Width to bearers shall be determined in accordance with the following diagram:

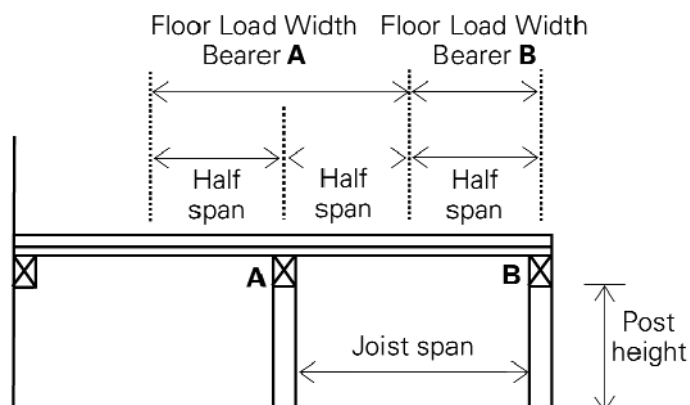

Prior to Construction

Under deck conditions

The area which will be under a completed deck shall be adequately graded, drained and ventilated so that the area is dry in normal conditions and dries quickly after wet weather without water pooling.

Retained humidity in the sub-floor area resulting from pooled water, damp soil conditions and/or a lack of sufficient ventilation can result in swelling and cupping of the decking, possible decay of the decking and/or structural framing members, and increased risk of termite attack.

Where the ground is excessively damp due to poor drainage or seepage, sub-surface drains should be installed to allow the moisture to drain away.

The presence of a differential moisture content between a dry (and possibly hot) top surface and a moist underside of a decking board is likely to lead to distortion of the decking within a short time.



On-site storage

LifePlus® Decking shall be protected from damage from both moisture and excessive heat, and packed up off dry ground to allow a free airflow, while stored on site prior to installation.

Any storage shed or protective cover must be waterproof, but should also provide for a free-flow of air so that the timber is not affected by excessive heat build-up or condensation.

Protective coverings must not trap condensation, and outdoor storage areas should be chosen so that there is no possibility of water pooling under the covers, which could result in moisture uptake into the boards.

Inadequate covering can result in:

- Water marking, which may remain visible under clear finishes;
- Moisture absorption, which can result in moisture induced movement;
- Excessive heat build-up, which can cause distortion of the timber.

Because of the potential for excessive heat build up, black plastic is not considered a suitable long-term covering.

Sealing cut-ends and joints

Seal all cut ends, checked joints and timber-to-timber interfaces in structural timber or detailed timberwork to reduce the absorption of trapped moisture, which may lead to accelerated deterioration of the timber.

In the case of a structure to be painted, the sealing of timber-to-timber interfaces during construction is particularly important, as trapped moisture which is absorbed into end or face grain cannot dry out through the paint film. Timber-to-timber interfaces include:

- A bearer or brace bolted to the face of a post;
- A joist end sitting on or butted to a bearer;
- A handrail butting onto a post;
- The face and ends of balustrading fastened to a handrail.

For pressure treated structural timber which is not to be later painted, a heavy bodied timber preservative such as CN Emulsion is an appropriate sealer, absorbing into and sealing the end or face grain. However, CN Emulsion will be noticeable as a darker coloured oily area around the joint. This darker coloured area may not be suitable for appearance and will stop paint adhering.

Alternatively, you could use a liberal application of an oil-based primer/undercoat as a sealer, coloured if required for appearance. An oil-based primer/undercoat is also suitable for sealing structural timber which is to be painted.

For detailed timberwork, such as handrail timbers or balustrading, any cut-ends, and the abutting surfaces should be sealed during construction. It is also good practice to leave a gap between the end of the balustrading and the bottom rail so that moisture which pools there can dry out.

The sealing of handrail components before installation is often neglected, leading to rotting of handrail and balustrade ends and the timber around fixings which can be unsightly and in the worst case can lead to loss of structural and fixing strength, increasing the risk of failure.

Refer to “Decking” for information on sealing decking.

Protective timber finishes

It is important that a suitable finish be applied and maintained to protect the surface of the timber from weathering and to maintain an attractive appearance.

Timber finishes are of two types:

- **Film Building Finishes**, such as paints, clear surface coatings and heavy-bodied stains - which form a surface film and do not penetrate significantly into the surface of the timber.
- **Penetrating Finishes** such as water repellents, decking oils and decking stains – which penetrate into the surface of the timber and do not form a significant surface film.

You should decide before commencing, where you will use a penetrating oil or stain, paint or heavy bodied stain, and consistently use that system for sealing and finish coats as you may not be able to change the system part way through. For example, a paint system may not be able to be applied over a preparatory oil or stain finish and similarly an oil or stain finish would not be effective if applied over a paint prime coat.

Paint finishes hide the natural appearance of timberwork. However, they provide high levels of weathering protection, provided they are properly applied and maintained. A paint system properly applied and maintained on structural timber can give protection for up to 8 years. Note - this does not apply to decking and possibly not to horizontal surfaces.

Heavy bodied stains also provide high levels of weathering protection but do not last as long as paints.

Decking oils and stains do not form a significant surface film and provide a more natural appearance. Decking stains generally contain coloured pigments and obscure the appearance of decking to a greater degree than decking oils, but provide greater protection and need recoating less regularly.

In "average" conditions, you should expect protection for 9 to 12 months from oils and 12 to 18 months from stains. In severe conditions, such as around pools, recoating is likely to be necessary at shorter intervals. Although decking oils and stains require recoating at relatively short intervals, the recoating process is relatively simple and speedy.

Because of the different properties and advantages of oils, stains and paints, it is common practice for exposed structural timber to be protected with a paint system for outward appearance and longevity, whilst the decking timber is protected with an oil or stain finish which has a more natural appearance and does not form a surface film which can be damaged or peel or become slippery when wet.

Concealed structural timbers, eg joists, are generally left uncoated with natural durability and sealing of the tops of the joists and end grains being sufficient to ensure suitable performance and longevity.

We would not recommend the use of a paint system for protecting decking as it can become slippery when wet and as the protection relies on the paint film remaining intact. Decking is subjected to foot traffic which can damage the paint film, allowing moisture penetration which can lead to deterioration of the decking, as moisture which is absorbed cannot readily escape and may also lead to further damage to the remaining paint film.

If you are committed to using a paint finish for decking, ensure that the manufacturer recommends the product for use as a timber decking finish and follow the manufacturer's recommendations carefully. Normal exterior paints are unlikely to be suitable for use as a decking paint.

If unsure, talk to your decking oil, stain or paint supplier about the properties and compatibility of different systems during your planning stage and before commencing construction.

Suitable fixings

All bolts, screws, nails, brackets, framing anchors and other hardware in fully weather exposed conditions should be hot-dipped galvanized or stainless steel (depending on conditions) to ensure satisfactory long-term performance of the fasteners.

Electroplated or zinc-plated fasteners are not suitable for long-term performance in fully weather-exposed conditions as the plating will deteriorate, particularly in contact with preservative treated timbers.

Commercially available framing anchors are generally made from lightly galvanised metal and are only recommended for use outside of the coastal zone, unless provided with additional protection, in weather protected areas eg. internally or under a roof with sufficient covering to prevent wetting of the deck. Additional protection of lightly galvanised brackets can be achieved with suitable preparation and coating with an epoxy paint such as Ameron Amercoat 385. Preparation is important as brackets are often coated with an oily film during

manufacture, which will prevent any additional protective coating from adhering.

If unsure, refer to your supplier for further information on suitability for exposed conditions.

Problems with inappropriate fasteners may not be apparent in the short or medium term. Corrosion of fixings can lead to long-term problems such as loss of hold-down forces to stop decking distorting or serious structural problems from the corrosion and potential failure of brackets or bolts supporting posts, bearers or joists.

In corrosive environments such as in coastal areas or around pools, all fixings, including connector nails, shall be stainless steel.

Existing garden features

Rather than cut down a favourite tree or destroy a rock feature, you can design the deck to allow the tree to grow through it or to follow the outline of the rock or other garden feature.

Before construction, consider whether your favourite tree needs pruning or removal for safety or the health of the tree. It will be easier and cheaper to prune or remove the tree before construction, when the tree pruner can work without concern about damaging your deck.

Draw your bearer and joist layout to trim around the rock or the trunk of the tree making sure you allow plenty of room for at least 20 years of growth in the tree and for swaying in windy weather. During construction, you can scribe the decking in around the feature, allowing room for a tree to sway. The decking can be trimmed back every few years if necessary as the tree grows. When setting out the joists and scribing the decking around the feature, ensure that you have allowed room for any waterborne dirt to flow away and not become trapped in the timber work as this can lead to accelerated deterioration.

Construction Stage

The following outlines the "joist-on-bearer" method of construction where the joists sit on top of the bearers.

The "joist in line with bearer" method, using metal joist hangers to support the joist so that the tops of the bearers and joists are at the same level, may also provide suitable long-term performance in weather exposed conditions where the deck is completely protected from the weather and not in a corrosive or coastal environment or where hot-dipped galvanized or stainless steel stirrups and fixings are used, in association with all other appropriate timber protection and construction techniques.

Setting Out

Using a tape measure, string line and level, locate the corners of the deck, setting up your forms and string lines to accurately mark the center-line of your posts as shown in Figure 1.

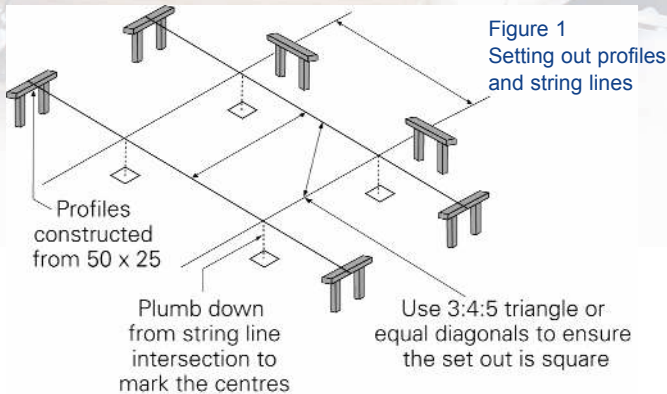

Square the corners using the 3-4-5 ratio* or equal diagonals method and level the string lines. Measurements along these lines will give the positions of intermediate posts and vertical measurements at these points can be used to determine the height of the bearers above the ground. Be sure to confirm that the drawings, profiles and siteworks are all referring to the same reference points. Also, be sure that your post positioning takes into account whether you will or will not be checking your bearers into the post.

*A right-angled triangle is formed if one side of the triangle is 3 units long (e.g. 1.5m), another is 4 units (e.g. 2m) and the hypotenuse is 5 units (e.g. 2.5m).

Footings

Timber posts should ideally be installed on commercial quality hot-dipped galvanised brackets cast into engineered concrete footings or, if necessary, extended into the footings.

Even hot-dipped galvanised brackets can corrode in contact with concrete, although such corrosion can take a long time to affect the strength of the bracket. It is advisable to apply an additional protective coating such as an epoxy paint eg Ameron Amercoat 385, to the galvanising which will be in contact with the concrete.

Position the bracket vertically so that the timber post will stand clear of the horizontal bar on the stirrup by 10mm, clear of the top of the concrete by 75mm and 100mm above ground level (bar clear of concrete by 65mm). See Figure 2.

Concrete around the post brackets so that the top of the concrete is above ground level sufficiently that dirt will not collect on top of the concrete (indicatively 25mm).

Trowel the top of the concrete neatly, graded with a "fall" outwards to allow water to run-off.

Check, re-position and plumb the post brackets before the concrete sets. See Figure 2.

After the post brackets have been correctly positioned and cast-in, reposition and level the string lines so that they indicate the outside edge of the posts and are out of the way of construction.

Timber posts extending into the footings shall be sealed below ground with CN Emulsion and set into "no-fines" concrete with a layer of "no-fines" concrete at the base, to allow water to drain, in accordance with the engineering design but a minimum of 100mm. Standard concrete can hold moisture around the post and cause accelerated deterioration. The top of the no-fines concrete shall be sealed with mortar and sloped away from the post to shed water. See Figure 2.

Allow sufficient time for curing before placing posts. The top of the no-fines concrete should be sealed with mortar and sloped away from the post to shed water. Termite treatment to embedded posts is to be in accordance with the Building Code of Australia and may include steel mesh socks &/or chemical treatment to the surrounding ground.

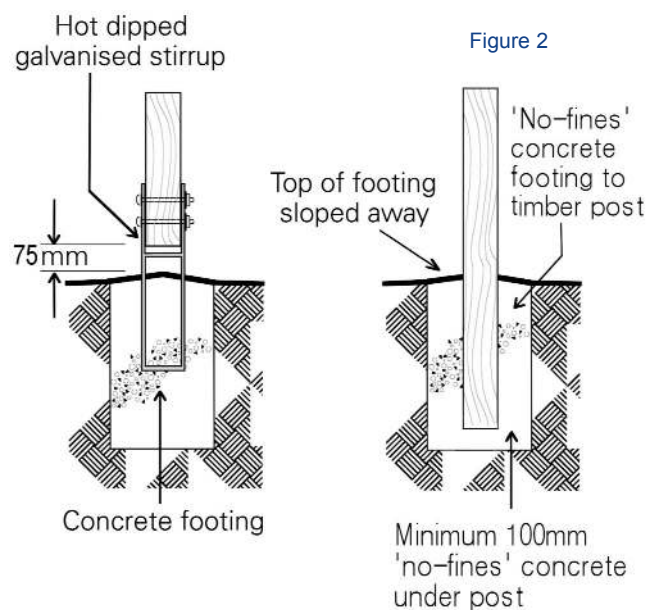

Posts and Ledgers/Pole Plates

After the concrete is 4 days old, bolt the posts to the brackets using 2/12 mm hot-dip galvanised hex-headed bolts, allowing a clearance of 10mm from the horizontal bar in the stirrup to the bottom of the post to allow any moisture which collects there to dry out. Seal the ends of the posts before installing them onto the brackets.

Where the house or adjoining structure is structurally adequate to support one side of the deck, a 100 x 50 mm ledger or pole plate can be used to support the joists fixed to the house framing with 12mm hot-dipped galvanised bolts or coach screws at maximum 600 mm centres. See Figure 3 (overleaf).

Figure 3

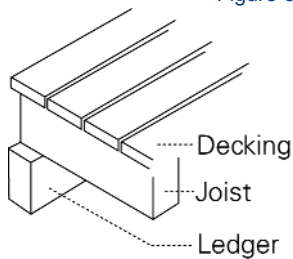

Note that single skin brickwork, including brick-veneer may not be structurally adequate to support a deck and additional piers or freestanding posts shall be incorporated into the design if required.

Bearers

Use a level (automatic or water level) to locate the position of the top of the bearer on the posts. Confirm the positioning of your bearers, that they are level and in their correct alignment, as this is the last chance you will have to easily adjust their position and that of the structure above.

Posts which are not continued as handrail or roof supports (as in figure 5) shall be cut off above bearer level to ensure minimum bolt end clearances. See Figure 4.

Where the bearer is to be bolted onto the face of the post - mark the position of the bottom of the bearer and securely clamp a timber block with a heavy securing nail onto each post at that point to support the bearer. Ensure that the block and securing nail will support the bearer before proceeding.

Where the bearer is to be checked into the post - mark the position of the bottom of the bearer and check out the post the required amount, but no greater than 1/2 of the depth of the post and leaving a minimum of 35mm of post remaining. Clamp the bearer securely before proceeding.

Apply a timber sealer to the bearer and post where they will be in contact, as moisture trapped at the interface may lead to accelerated deterioration. Sealing checked joints is particularly important, as moisture will penetrate into end grain to a greater degree than face grain, increasing the risk of rotting.

Place the bearer onto the supporting block or into the checked joint, hold safely and clamp the bearer to the post. Mark the position of the bolt-holes and drill through the bearer and continue through the post.

A splay joint may be used where bearers are joined at a post. See Figure 4.

Alternative methods for creating joints in bearers over posts are described and illustrated in Australian Standard 1684.2 - 4.2.

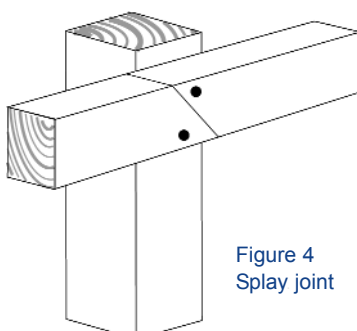
Figure 4
Splay joint

Bolt the bearer at each post using 2/12mm hot-dipped galvanised cup-head bolts and washers.

Trim off the bearer ends, flush with the end support posts or cantilever the bearer up to the maximum allowed in Table 2.

Seal the top edge of the bearer, before placing the joists, to reduce water penetration and accelerated deterioration. A heavy coat of CN Emulsion, or one coat of oil based primer plus one coat of paint finish, or applied to the top of the bearer will act as a suitable sealer.

Joists

Seal the underside of the joist, extending out 50mm, where it will be in contact with the bearer.

Mark the position of the joists on the bearers using a string line and tape measure. Set out the joists over these marks making sure you place any curved timber so the bow is up and the ends point down.

Check that the finished deck is level and will be lower than the internal house floors once the decking has been installed. See Figure 5. The deck joists may naturally be suitably smaller than the house joists if the deck span is smaller than the house span. Alternatively, if the deck and house joists are the same size, the deck joists can be reduced in depth (notched or gauged down) by a maximum of 1/4 of the depth of the joist (so that the remaining section is a minimum of 3/4 of its original depth). See Figure 5.

Decking joists parallel to line of internal joist

Figure 5 Joist set-down and deck framing

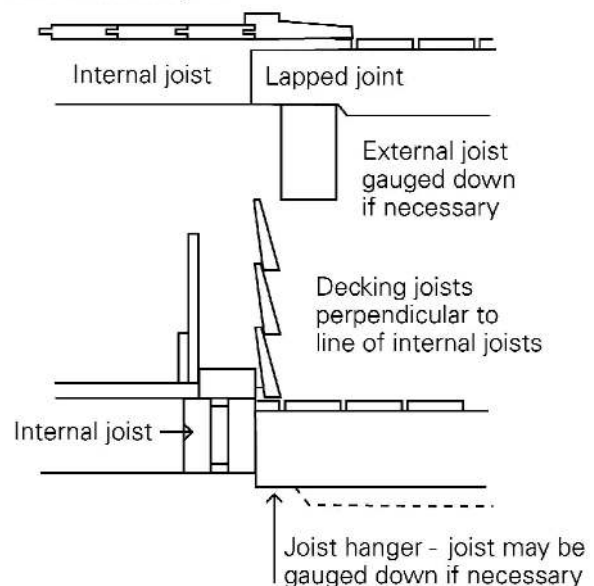

Fix the joists with 2/75 mm galvanised skew-nails or proprietary hot-dipped galvanised or stainless steel or epoxy-coated framing anchors. Trim off the joist ends, flush with the bearer and cover with a fascia or cantilever the joists up to the maximum allowed in Table 3. See Figure 6 (overleaf).

Figure 6 Deck and pergola detail

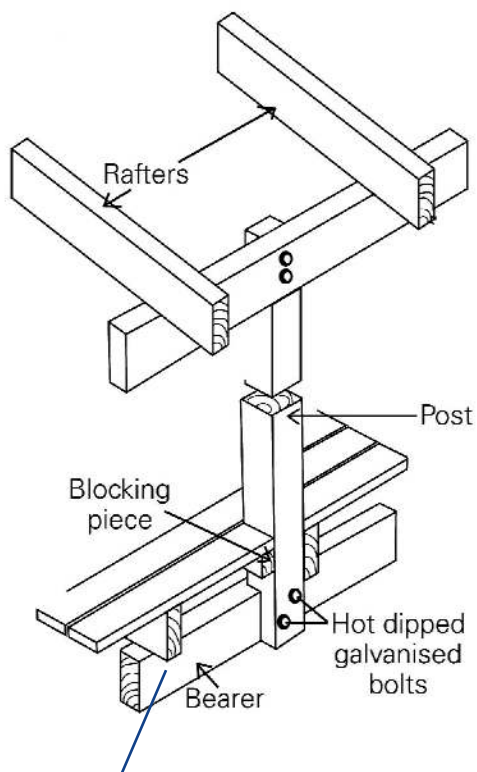

Cut joists over length to extend past bearer or cut flush and cover with fascia.

Bracing

Decks on columns shall be braced to prevent lateral movement in accordance with AS 1684.2 - 1999. Bracing shall be minimum of double diagonal 100x50mm minimum F14 hardwood braces, halved at the crossing. See Figure 7.

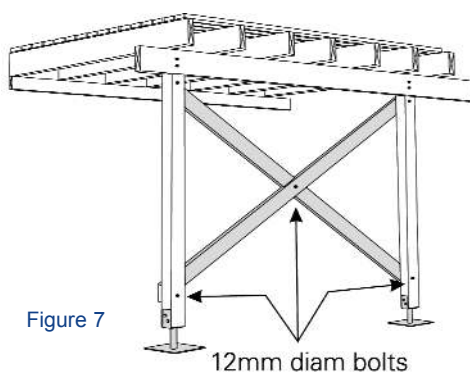

Figure 7

Decks attached to the house, shall have double diagonal bracing, either:

- Fixed to the underside of the joists with each brace fixed to each joist with 75 mm No. 14 Type 17 galvanised batten screws. See Figure 8, or
- For decks greater than 1800 mm high, fixed between a pair of posts, parallel to the wall, with the ends of braces bolted to posts with 12mm diameter galvanised bolts.

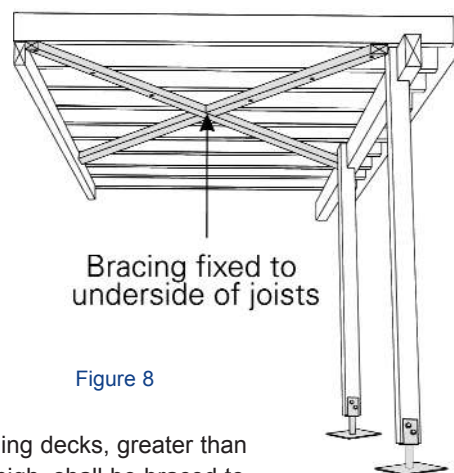

Figure 8

Freestanding decks, greater than 1800mm high, shall be braced to prevent movement in both directions with double diagonal braces between at least two pairs of posts at right angles (timber and bolts as previously). Freestanding decks, less than 1800mm high, shall have posts embedded in the ground to provide lateral bracing.

We recommend the use of timber, rather than threaded rod, for bracing, as timber braces provide a more rigid bracing effect than some alternatives and will not "sing" in windy conditions.

Decking

Specify **LifePlus® Decking** for high performance and long lasting decking timber.

Pre-treatment of LifePlus® Decking

We recommend the use of penetrating oil or stain finishes to protect decking from weathering. To achieve maximum life from your decking, apply an appropriate sealing coat to all surfaces, including cut-ends, before laying.

Note: Apply the sealer liberally to the absorbent end grain. An exterior polyurethane will provide a more effective and longer lasting end grain seal - applied carefully so as not to coat the faces of the board.

For a decking oil or stain, use one coat of the intended finish as a sealer. If using a stain finish, be careful not to overload the surface, and to brush out any excess stain. Refer to "Finishing of LifePlus® Decking" for more detail.

Clear film building decking finishes may require a period of seasoning or surface preparation before applying the finish. Refer to the manufacturer's recommendations to determine if pre-treatment is suggested before laying.

We do not recommend the use of a paint finish for sealing decking. If a paint finish is required, refer to your paint supplier for recommendations on sealing and finishing decking.

Whether a decking oil, stain, or paint finish is to be used, read carefully and adhere to, the manufacturer's recommendations for application of preparatory and finish coats to achieve the best result.

Installation of LifePlus® Decking

Before fixing the decking, seal the top edge of each joist with either CN emulsion, a primer plus finish coat or, as we strongly recommend, a waterproof membrane (such as Malthoid, a bituminous dampcourse), for a more effective seal which will also reduce water entry around the fixing and shed water from the joist.

CN Emulsion, applied to the top of joist, may be absorbed upwards, causing an oily mark on the top surface around fixings and at butted joints in the decking. Regular application of a decking oil or stain will make any oily mark less apparent, however if this is likely to be an issue in terms of appearance, use an alternative sealing method.

As advised in "Pre-treatment of LifePlus® Decking", **apply a sealing coat to all surfaces of the decking, including cut-ends, prior to laying.**

Consider your required edge detail eg covering a fascia capping board and/or with a small nosing and determine the position of your outer decking board, but do not fix it initially. Run a string line one board-width in from the outer edge of the joists. Drive a positioning nail into each joist along the string line and place the first board hard against these nails before fixing, using nails as per Table 4 (page 10) and fixing instructions as outlined below. After removing the positioning nails, touch up the holes created in the joist with the chosen sealing system.

Lay the remaining boards, using spacer blocks to create a 3 to 5 mm gap between adjacent boards to allow for swelling and shrinking in response to changes in atmospheric moisture content, water runoff and cleaning.

Small differences between the moisture content of the decking as supplied and the local EMC can be allowed for by applying a gap at the lower end of the range if the decking is likely to shrink, or at the upper end of the range if your deck is likely to swell.

In determining whether the moisture differential will cause movement in the decking, confirm the moisture content by accurate measurement of the decking boards supplied.

Boards shall not be butted together in anticipation of significant shrinkage, or laid with a large gap in anticipation of significant swelling. If significant shrinkage or swelling is expected, decking with appropriate moisture content shall be sourced or standard moisture content decking acclimatised on site prior to laying.

Note: Do not use nails as spacers as the nail holes can be a source of moisture entry and degrade.

Butt joints shall be staggered so that they do not occur on adjacent boards.

Butt ends should be cut with a slight backward undercut to assist in achieving a tight fit (see Figure 10). The slight gap created by the undercut will also reduce the potential for premature deterioration of the board ends as less moisture will be trapped and absorbed into the end grain, and assist in ventilation of the board ends, allowing any moisture which has been absorbed to dry out more readily.

Regularly check that the boards are running true by measuring to the opposite or inner edge of the deck and by running a string line. For a deck with square ends, one end treatment is to lay boards over-length, mark with a string line and trim them all off in one neat cut. Another method is to fix a trimming board at right angles to the direction of the run of boards and cut each end board to length to suit.

Fixing of LifePlus® Decking

Selection of the correct fixing and fixing method is critical to the satisfactory long-term performance and appearance of timber decking.

In weather exposed domestic applications subject to light foot traffic, LifePlus® Decking shall be hand nailed or screwed with two fixings per board at each joist. Nails shall be domed head (DH), twist shank (TS) type in stainless steel (SS) (preferred) or hot-dipped galvanised (HDG) (depending on severity of exposure conditions).

**For hardwood joists, use 50x2.8mm DHTS nails (as above)
For softwood joists, use 65x3.15mm DHTS nails (as above)**

Twist shank nails provide a stronger and longer-lasting fixing than traditional hot-dip galvanised bullet head nails.

Alternatively, use 50 x 10G LifePlus Decking Screws (stainless steel with square drive and self-embedding head) for improved hold down, corrosion resistance and resistance to working out.

T-Nails (eg 50x2.2 Finishing Nails or 50x2.5 Flooring Nails) shall not be used to fix decking as the zinc plating may deteriorate rapidly and the shank diameter is insufficient to provide suitable hold-down, resulting in boards moving or 'rocking' and nails working up.

Figure 9

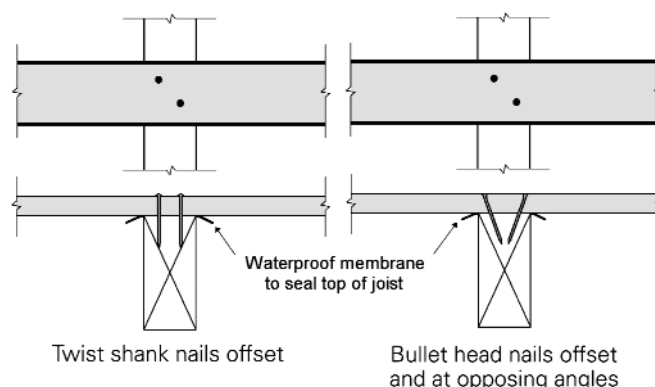

Plain steel or zinc plated nails shall not be used to fix decking or in any external application, as they are likely to rust, causing staining and gradual deterioration of the nail and the timber around it.

Decking should be drilled with a small pilot hole to avoid splitting.

If a pilot hole is required in the joists, the hole should be of suitable size and depth, to provide maximum hold-down force while allowing the nail to be driven without bending and without damaging the nail head.

The need for, and size of, a pilot hole will vary between timbers, depending on hardness and may not need to be drilled full depth. Determine the need for, and appropriate size and depth of, a pilot hole for your timbers by testing with off-cuts of decking and joists.

To reduce the possibility of splitting the joist, the nail or screw fixings shall be placed in a formal and controlled staggered alignment. Nails shall be fixed with a 10 to 12mm stagger, with a minimum of 12mm edge clearance). Refer to screw installation recommendations for required screw edge clearance and stagger.

Where decking boards terminate or are joined at a joist, domed head nails should be 12mm from the end of each board, with the board predrilled to 80% of the domed head nail diameter to avoid splitting. Nails may have to be skewed slightly inwards to achieve the necessary clearance to the end of the decking board and edge of the joist. See Figure 10.

Figure 10

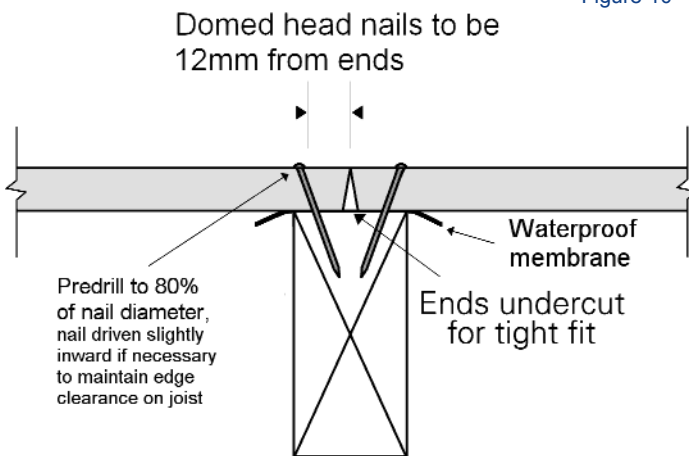

If galvanised bullet head nails are to be used for fixing LifePlus® Decking, in weather protected domestic applications, the nails shall be in a formal staggered

alignment and driven inward at an angle towards the centre of the joist (ie as skew nails). See Figure 9.

Decking fixings placed in a straight line are likely to split the joist. Split joists are likely to result in:

- a reduction or total loss of hold-down forces, allowing movement and distortion in the decking;
- nails “walking-out” of the deck as the decking moves under foot traffic;
- accelerated deterioration of the joist as water enters the split and is not able to dry out readily.

Nails, whether domed or bullet head, should be driven only so that the head pulls the board down tight onto the joist. Nails shall not be punched into or below the decking surface.

- “Punching” of bullet and domed head nails will leave a depression in which water can pool and soak into the timber, accelerating deterioration. As the exposed surface in the depression is largely end grain, water will soak into it rapidly but will not dry out readily which will lead to rotting of the timber around the entry hole and nail shank, and reduction of hold down force. If the nail head becomes slightly “proud” of the surface, due to the board or joist shrinking, the nail can be lightly driven, after, say, 6-9 months (under normal conditions), so that it is again flush with the surface.
- “Punching” of domed head nails will also severely damage the timber around the head.

LifePlus® Decking used in light-duty commercial applications subject to medium volumes of foot traffic shall be fixed with twist shank nails (as above) or 50x10G LifePlus Decking Screws as determined by the designer.

For commercial applications subject to high volumes of foot traffic use commercial standard decking and fixings.

Finishing

Effective initial finishing and regular ongoing maintenance is essential to protect LifePlus® Decking and the structural timber from the damaging effects of weathering and to maintain an attractive appearance.

Weathering of unprotected timber will result in colour change, a loosening of the timber fibres and a gradual wearing away of the surface, from the combined effect of exposure to water from rainfall and ultra-violet (UV) radiation in sunlight.

Unprotected timber will swell and shrink as moisture is absorbed and lost in response to local changes in atmospheric humidity or direct wetting. The UV radiation in sunlight will gradually turn the surface of unprotected timber to a silver-grey colour.

Uncoated timber remaining damp for extended periods, or in areas of high humidity, may also develop dark discolouration due to the presence of surface mould.

Vacuum pressure impregnation (VPI) treatment of LifePlus® Decking is intended to protect the sapwood from insect attack and decay and does not provide protection against the damaging effects of weathering.

Note that whether a decking oil, stain, or paint finish is to be used, the manufacturer's recommendations for application of preparatory and finish coats should be followed carefully to achieve the best result.

Finishing of LifePlus® Decking

Decking is particularly susceptible to weathering damage and particular care should be taken in its finishing and maintenance to ensure performance and longevity.

With its thin section, decking is likely to experience a greater reaction to changes in atmospheric moisture. Boards will tend to swell, as they absorb moisture in wet weather and shrink as they dry out, producing small cracks (surface "checks"), and possibly cupping. As decking is oriented with its larger dimension horizontal, it is also more exposed to the effect of direct sunlight and more likely to absorb moisture as water pools on its surface. LifePlus® Decking and the LifePlus® Decking System have been developed to reduce the damaging effects of weathering.

LifePlus® Decking is preservative treated with a formulation that does not contain a water repellent, as the approved hardwood species have good weathering characteristics and boards typically include only small amounts of sapwood.

Natural finishes should be commercial formulations meeting the requirements AS 1607.

Raw Linseed oil, or mixtures containing raw linseed oil, can encourage mould growth in timber and should not be used as a natural finish unless contained in a commercial product containing mould inhibitors. Mould growth will discolour the timber and removal of mould is difficult. It is often necessary to scrub the decking with a timber cleaning solution and stiff brush before re-coating.

Clear film building decking finishes, properly prepared, applied and maintained, as a system, can give good service over a long life although are likely to be more slippery in both dry conditions and exposed conditions when the surface is wet. Clear film building finishes should only be used where slipping is not an issue. Applying film building finishes without attention to the whole system may result in unsatisfactory performance and reduced life.

Understand and put into practice the preparation, application and maintenance instructions provided by the manufacturer. Refer any queries to your supplier or manufacturer.

Decking in weather exposed conditions, should not be coated with any finish that leaves a gloss coating on the surface as the deck may become slippery and difficult to traverse, especially in wet weather.

Seasoned timber may rapidly absorb the solvent or "carrier" from the first coat of a paint finish, providing an unstable foundation for further coats. Seek advice from your supplier whether an adjustment to the normal application technique is required for painting seasoned timber.

In areas of high temperature, pale coloured finishes are recommended, as they reduce the possibility of board distortion and premature deterioration of the finish due to excessive heat absorption.

Application of oil and stain finishes

Remembering that the decking has been sealed with a preparatory oil or stain coat, all round including liberal application to the end grain prior to laying, **once the decking has been laid, apply another liberal coat of the chosen oil or stain finish to the exposed surface.** Refer to the manufacturers recommendations as to whether a third coat would be beneficial.

The finish should be applied to a run of three to four adjacent boards along the full length of the deck, and not across the width. The gap between the boards can then be used to separate each run, so as to avoid overlapping of stain finish, which would result in a variation of colour density.

Only apply as much finish as the timber will absorb. Do not load the applicator too heavily and push the finish well out along the timber. "Back brush" the coated area to push the finish into the surface. After allowing a short time for the finish to absorb, but while it is still wet, "dry brush" the coated area to even out any patchiness resulting from irregular application or variations in the rate of absorption into the timber. If more finish has been applied than the timber will absorb, brush any excess onto unpainted sections or remove by wiping with a soft cloth.

A common problem with the application of stain finishes, is that the stain is applied too heavily and is not completely absorbed into the timber as it should be. "Overloading the surface" covers the grain of the timber, and produces a stronger colour than intended when the stain was selected. The resulting "surface coating" is often glossy and uneven (blotchy), is unstable, slippery and will weather off unevenly.

As an oil finish penetrates more readily than a stain finish, it is likely that more oil would be required for the same area and unlikely that an uneven appearance would result with reasonable care in application.

Application of paint finishes

We do not recommend the use of a paint finish for sealing decking. If a paint finish is required, seek advice from your supplier on sealing and finishing decking.

Finishing of structural timber

Remembering that any timber-to-timber interfaces have been sealed with an appropriate sealing coat to prevent trapped moisture causing accelerated deterioration, preparatory and finish coats can now be applied to protect structural timber from the effects of weathering.

Discuss with your paint supplier, appropriate products and correct surface preparation and application techniques for sealing, prime and finish coats to gain good performance and longevity from your finish coat.

Handrails

Refer to your local authority for the specific requirements for handrails for your deck. In general

- A handrail is usually required when the distance from the deck to the ground below exceeds 1m.
- The height of the handrail above the deck should not be less than 1m.
- The width of any open spaces in the balustrade should not exceed 125mm.
- Restrictions may apply to horizontal elements.

Decorative handrail such as 'bread loaf' and 'ladies waist' will span a maximum of 2.4 metres in Hardwood. The handrail

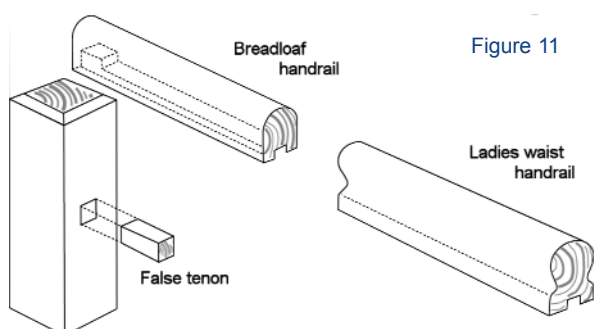

Figure 11

can be fixed to the posts with either heavy gauge, galvanized skew nails, galvanized metal brackets or false tenon joints which are available from your local building supplies store. See Figure 11.

If intending to use the handrail panels as a safety fence around a swimming pool, ensure the panels comply with pool fence safety requirements.

Care of your deck

The main enemy of an exposed timber deck is moisture. Except for the effects of weather over which we have no control, wherever possible keep your deck dry.

Decks should not be hosed down or subjected to regular wetting from irrigation systems. Pot plants should be placed in drip trays standing on small cleats clear of the deck. Any leaf material and debris should be broomed off at regular intervals.

Maintenance

To achieve satisfying long-term performance from timber decking, perform regular and effective maintenance including re-application of the decking finish at appropriate intervals. Decking in weather-exposed or severe conditions will require reapplication of the decking finish at shorter intervals than in protected conditions. Preparation and reapplication shall be carried out in accordance with manufacturer's recommendations.

Oil or stain finishes should be re-applied while the timber retains some water repellency. Water 'beading' on the surface indicates that the water repellency is effective. Water absorbing into the surface indicates that the water repellency is being reduced or has been lost.

As mentioned previously in "Protective Timber Finishes", in "average" conditions, you should expect protection for 9 to 12 months from oils and 12 to 18 months from stains. In severe conditions, such as around pools, recoating is likely to be necessary at shorter intervals. For best protection, finishes should be reapplied in the period before the most severe weathering conditions.

Generally, decking which has had the greatest weather exposure will be "drier" and may absorb more of the finish during recoating, with less (or in some cases negligible) absorption in protected areas. Make an allowance for this varying absorption when re-coating so as to avoid overloading the surface in the protected areas.

Decking Oils generally contain UV inhibitors, which may slow the natural greying of timber over time. If decking timber has begun to turn a silver grey, the colour can be restored by the application of a coloured decking stain, which is best applied at appropriate intervals before a strong grey colour develops. Greying of timber will still occur under a roof, however it will take longer as the UV exposure is less direct.

If a paint system has been used, take care not to damage the paint film, repair any damage as soon as it is apparent and re-coat the finish while in good condition.

It is important that re-application of a paint finish occurs while the finish is in good condition, as water pooling on the horizontal surface of a deck can penetrate a damaged finish accelerating deterioration of the finish and decking. A damaged finish can require intensive preparation in terms of sanding and repriming.

Some raising of the timber grain may be experienced on the exposed face from weather exposure. If this occurs, a moderate hand or machine sand will remove the raised grain in the affected areas. Regular re-application of the finish coats, as recommended, will act to protect and nourish the decking and reduce the incidence of raised grain. Usage will also tend to wear off raised grain.

Safety

Last but most important.¹²

Building a timber deck can be a rewarding experience, in creating an outdoor area which will be enjoyed over many years. The popularity of reality renovation television programs has glamourised DIY to such an extent that it makes construction work seem quick and easy. However, building a deck is a real construction project which will take time to complete and which has associated risks and complexities.

To ensure that building your deck is as rewarding as you anticipate it will be, pay careful attention to safety during construction.

Working practices, site organization and site access shall comply with Workplace Health and Safety Requirements. Wear suitable safety equipment when appropriate eg snug fitting work gloves to avoid splinters, eye protection when using power or striking tools, ear protection when appropriate, and a dust mask if creating airborne dust of any kind eg by hand or power saw, grinder etc.

Pay particular attention to safe practices when using ladders, grinders and power saws (tools which are the cause of many DIY accidents). Read and adhere to the safety advice which is provided on the product or in the product manual. Always ensure you are working on and from solid surfaces and that you have good control of any tool.

Exercise care when lifting, carrying and twisting under load.

Apply a disciplined approach to keeping the area tidy, free of waste or excess materials which could be a tripping hazard. Stack building materials securely and prevent access to the

¹² It may appear that we are being overly cautious regarding safety, however, in an article in the 'The Age' newspaper (August 8, 2004) it was reported that, in Victoria, over 1,000 DIY renovators sustained injuries requiring hospital treatment in 'the past year' – July 2003 to June 2004, not including GP visits. The Victorian experience has been extrapolated to estimate that 10,000 home renovation accidents occurred in Australia in that period.

site by unsupervised children.

If you are not a professional tradesperson or experienced handy person, work into the project slowly to get the feel of it, to become comfortable with the requirements and to establish good judgement when using hand and power tools.

Do not burn any treated off-cuts as this may create toxic vapours. Dispose of any treated off-cuts in landfill. In handling treated timber, use normal hygiene practices and wash hands before eating, drinking or smoking.

Anticipate what could go wrong in each situation and make appropriate changes to reduce risk to the maximum extent possible.

A DIY injury prevention brochure can be found at: www.general.monash.edu.au/muarc/diyhome.pdf
Refer to the [LifePlus® Decking](http://www.lifeplus.net.au) website (www.lifeplus.net.au) "Information" page for a link.

In conclusion, combining [LifePlus® Decking](http://www.lifeplus.net.au) with good decking design, other quality and suitable materials and good, safe construction, installation, finishing and maintenance practices will ensure that your timber deck will provide a satisfying and lifestyle enhancing experience over a long life.

Acknowledgments

Timber Innovations Pty Ltd acknowledges and appreciates the contribution made by Timber Queensland Ltd in permitting extracts and diagrams from a number of its publications to be reproduced in this document. For access to Timber Queensland publications visit www.timberqueensland.com.au.

Timber Innovations also acknowledges and appreciates the contribution made by Arch Chemicals in the preparation, formatting and development of artwork for this document.

Please note that the information and recommendations contained herein have been prepared with due care for the purpose of providing useful information to assist in the delivery of timber decking projects which perform well over a long life.

Whilst every effort has been made to ensure the accuracy of these recommendations and their consistency with current best practice, Timber Innovations Pty Ltd and Timber Queensland Ltd accepts no responsibility, liability or claims, for errors in or omissions from, these recommendations, nor for work done or omitted to be done, in reliance on these recommendations.

All diagrams are general representations and do not take the place of formally designed and detailed diagrams developed for local authority approval of a decking project.

LifePlus[®] Decking Guide

Notes Page





LifePlus[®] Decking Guide

Timber Innovations Pty Ltd

**10 Hobson Court
Chapel Hill Qld 4069**

Phone + 61 7 3878 2053

Fax + 61 419 725 779

Email jgstubb@bigpond.net.au

www.lifeplus.net.au